

ANALYSIS OF THE RESULTS OF EXPERIMENTAL RESEARCH OF THE DESIGN OF A GEARED-ROLLER MECHANISM WITH A FLEXIBLE ELEMENT

Akbarjon Jumaev

Almalyk State Technical Institute, Almalyk, Uzbekistan
Doctor of Philosophy (PhD) in Technical Sciences, Associate Professor
ORCID: [0009-0009-3026-8052](https://orcid.org/0009-0009-3026-8052); E-mail: akbarjumayev011@gmail.com

Muxammadali Ermatov

Almalyk State Technical Institute, Almalyk, Uzbekistan
Student of the 7-24 MM group, Mechanical Engineering
E-mail: kechaziy@gmail.com

Abstract: This paper presents an analysis of the results of experimental studies on the design of a gear mechanism with a flexible element. The research includes the determination of the main operating parameters, investigation of structural features, as well as kinematic and dynamic analysis of the mechanism. Based on the obtained experimental results, scientific and technical solutions aimed at improving the performance and reliability of the gear mechanism are proposed. The research findings are of practical importance for the design and optimization of gear mechanisms.

Keywords: flexible element, gear mechanism, parameters, structural analysis, kinematic analysis, dynamic analysis, experimental research, scientific and technical solutions.

Annotatsiya: Ushbu maqolada qayishqoq elementli tarkibli tishli g'ildirakli mexanizm konstruksiyasining tajribaviy tadqiqotlari natijalari tahlil qilingan. Tadqiqot jarayonida mexanizmning asosiy ishchi parametrlarini aniqlash, uning strukturaviy xususiyatlarini o'rganish, shuningdek kinematik va dinamik tadqiq qilish ishlari amalga oshirilgan. Olingan natijalar asosida mexanizmning ish samaradorligini oshirishga qaratilgan ilmiy-texnikaviy yechimlar taklif etilgan. Tadqiqot natijalari tishli mexanizmlarni loyihalash va takomillashtirishda amaliy ahamiyatga ega.

Kalit so'zlar: qayishqoq element, tishli g'ildirakli mexanizm, parametrlar, strukturaviy tadqiqot, kinematik tadqiqot, dinamik tadqiqot, tajribaviy tahlil, ilmiy-texnikaviy yechimlar.

Аннотация: В статье представлен анализ результатов экспериментальных исследований конструкции зубчатого механизма с упругим элементом. В ходе исследования выполнено определение основных параметров механизма, изучены его структурные особенности, а также проведены кинематические и динамические исследования. На основе полученных экспериментальных данных предложены научно-технические решения, направленные на повышение надежности и эффективности работы механизма. Результаты исследования могут быть использованы при проектировании и совершенствовании зубчатых передач.

Ключевые слова: упругий элемент, зубчатый механизм, параметры, структурное исследование, кинематическое исследование, динамическое исследование, экспериментальный анализ, научно-технические решения.

Today, scientific research is being carried out at mining enterprises to create new effective designs of gear and flexible joint mechanisms widely used in technological machines, to conduct structural, kinematic and dynamic research to substantiate their parameters, and to develop their scientific and technical solutions. In this regard, special attention is paid to creating designs of gear reducers with composite, flexible

elements used in technological machine drives in mining production, reducing friction, wear and noise in gear mechanisms, and substantiating their technological operation processes and parameters.

As a result of experimental research, it was determined that the experimental version of the proposed reducer of the brand I2Y-160 provided for the determination of the torques, rotation frequencies and noise on the driven and driven shafts, taking into account the vibration amplitude of the gear wheel and the material of the gear wheel with a flexible element, rubber grades of different densities. The experiments were carried out at different working capacities [1, 2].

As noted above, in order to increase the operational performance of the reducer of the brand I2Y-160, a mechanism was used in the transmission mechanism, which included a gear wheel with a ring bushing with a flexible element. The gear wheel with a flexible element with the proposed gear wheel was manufactured using special press forms (Fig. 1).

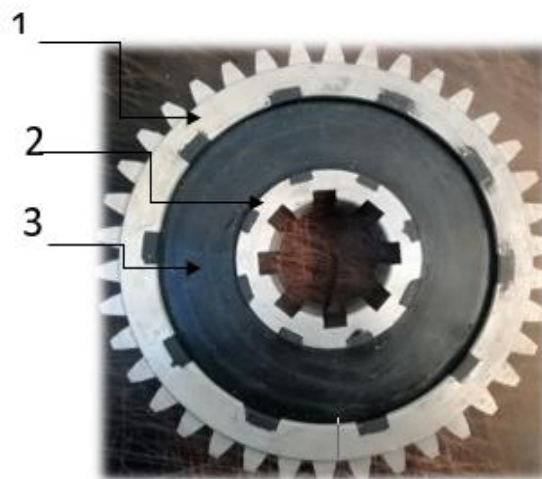

1-component gear wheel gear flange, 2-ring rubber bushing, 3-inner ring.

Figure 1. View of a gear wheel with a component belt element.

An electrotensometric scheme of the experimental stand of the I2Y-160 reducer, which transmits movement from one mechanism to another, was developed (Fig. 2). When the experimental stand is started, the electric motor 1 transmits the movement to the driving pulley 2 through the belt drive 3 and the driven pulley 4 to the driving gear 5. Then it transmits the movement to the gear 6 with the recommended belt element, and the movement is transmitted to the third gear 7. The movement is

transmitted to the brake drum 9 through bearings 8 fixed at both ends of the shafts. To measure the required values, data is transmitted to the computer through special sensors, such as Kvars and vibXpert 10, which are connected to the shaft in a half-bridge manner. These universal sensors allow measuring the torques, angular velocities, and noise on the shafts with the appropriate accuracy [3, 4].

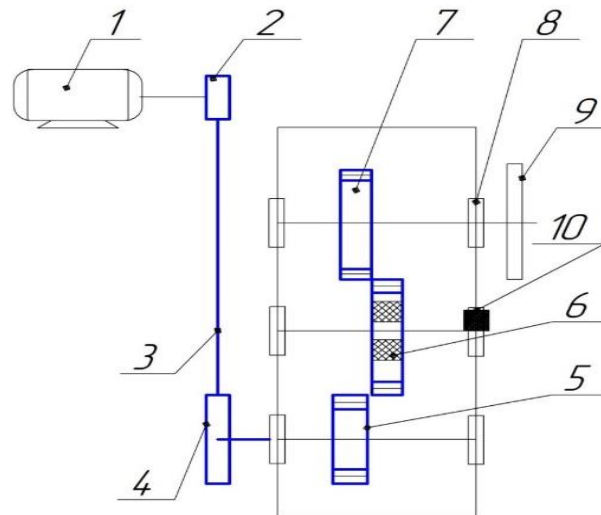

1-electric motor, 2-driving pulley, 3-gear, 4-bearing, 5-brake drum, 6-vibXpert universal measuring instrument sensor, 7-gear wheel with belt element, 8-gear wheel, 9-belt, 10-driving pulley

Figure 2. Electrotensometric scheme of the experimental stent of the reducer brand И2Y-160

In order to increase the accuracy of the results obtained, the tests were repeated 3 times in the same mode.

Using a complex measuring instrument, the angular velocity, torque and noise of the shafts of the driving and driven gears of the modernized two-stage reducer of the И2Y-160 type with a gear wheel with a rubber bushing were determined by the tensometric method [5, 6].

Graphs of the dependence of the angular velocities of the input gear wheel shaft, the belt element and the output gear wheels of the modernized И2Y-160 type reducer installed in the transmission of the “Valuts” technological machine on the change in the friction torque on the working drum were constructed. It was found that when the depreciation belts are passed through the working drums in the technological machine, the increase in the technological resistance from them leads to a decrease in the angular velocities of the shafts in a nonlinear manner.

REFERENCES

- [1]. Djuraev, A., Jumaev, A.S., Ibragimova, N.I., Turdaliyeva, M.Y. Analysis of the dynamics of a belt conveyor with composite guide rollers and elastic elements. *Journal of Physics: Conference Series*, 2023, 2573(1), 012026.
https://api.scienceweb.uz/storage/publication_files/9737/26378/666ad94ba5c1b
- [2]. Abduvaliev, U., Jumaev, A., Nurullaev, R., Ashirov, A., Abdurafikov, B. Influence of the Sectional Shape of the Grabbing Element of a Screw Composite Spindle on Agricultural Performance and Stability of Operation of a Cotton-Picking Machine. *Lecture Notes in Networks and Systems*, 2024, 1129.
https://link.springer.com/chapter/10.1007/978-3-031-70670-7_25
- [3]. A. Djuraev, B.N. Davidbaev, A.S. Jumaev. Improvement of the design of the belt conveyor and scientific basis for calculation of parameters. Global Book Publishing Services is an International Monograph & Textbook Publisher. Copyright 24 may 2022 by GBPS. 10.37547/gbps – 03. 1211 Polk St, Orlando, FL 32805, USA. – 151 p.
- [4]. Djuraev, A., Jumaev, A.S., Abduraxmanova, M.M. Analysis of the results of physical and mechanical experimental studies of the modernized belt conveyor. *Journal of Physics: Conference Series*, 2023, 2573(1), 012012.
<https://iopscience.iop.org/article/10.1088/1742-6596/2573/1/012012>
- [5]. A. Djuraev, Sh. S. Khudaykulov, A. S. Jumaev. [Development of the design and calculation of parameters of the saw cylinder with an elastic bearing support jin.](#) *International Journal of Recent Technology and Engineering (IJRTE)* ISSN: 2277-3878, Volume-8 Issue-5, January 2020. <https://www.ijrte.org/portfolio-item/E6952018520/>
- [6]. Jumaev, A., Istablaev, F., Dustova, M. Development of the theory of calculation of constructive and rational parameters of belt conveyor roller mechanisms. *AIP Conference Proceedings*, 2022, 2467, 060025.
https://api.scienceweb.uz/storage/publication_files/9737/26397/666af69e34968.
- [7]. Abduvaliev, U., Jumaev, A., Nurullaev, R., Jakhonov, S., Investigation of the process of the influence of winding spindles with cotton fiber on the performance of a cotton picker. *E3S Web of Conferences*, 2024, 548, 04013. https://www.e3s-conferences.org/articles/e3sconf/abs/2024/78/e3sconf_agritech_x_04013/e3sconf_agritech-x_04013.html.
- [8]. Tilabov, B., Jumaev, A., Sherbutaev, J., Normurodov, U., Salimov, G. Testing of heat-treated surfaced samples and machine parts for hardness and wear resistance. *E3S Web of Conferences*, 2024, 548, 03014.

https://www.e3s-conferences.org/articles/e3sconf/abs/2024/78/e3sconf_agritech-x_03014/e3sconf_agritech-x_03014.html

- [9]. Jumayev A.S., Abduraxmanova M.M. [Modernizatsiya qilingan tasmali konveyer rolikli mexanizmlarining tajribaviy tadqiqot natijalari tahlili](#). Scientific Journal of Mechanics and Technology. ISSN 2181-158X, volume 6, Issue 1, 2025.
- [10]. Djuraev, A. Jumaev. [Providing the development of new designs for the design of the roller mechanism transmitting rotational motion in belt conveyors](#). International Journal of Emerging Trends in Engineering Research. ISSN 2347 – 3983. Volume 8. No. 9, September 2020.
- [11]. A.S. Jumaev, A. Djuraev, M.M. Abduraxmanova. [Analysis of the influence of the properties of oil products on the performance of belt conveyor guide roller mechanisms](#). Harvard Educational and Scientific Review International Agency for Development of Culture. Vol.2. Issue 2 Pages 44-52. 2020.
- [12]. A.S. Jumaev, A. Djuraev, A.N. Pushanov. [Development of models of recession of defatory states of components as a result of external loads of belt conveyor drums](#). Harvard Educational and Scientific Review International Agency for Development of Culture. Vol.2. Issue 2 Pages 36-43. 2020.
- [13]. A.D. Djuraev, A.S. Jumaev. [Study the influence of parameters of elastic coupling on the movement nature of support roller and rocker arm crank-beam mechanism](#). International Journal of Advanced Research in Science, Engineering and Technology Vol. 6, Issue 6, June 2019.
- [14]. A.S. Jumayev. [Tasmali konveyer rolikli mexanizmlarini resurstejamkor konstruksiyalarini ishlab chiqish va nazariy tahlil qilish](#). Scientific journal of mechanics and technology ISSN 2181-158X, volume 5, Issue 1, 2024.